

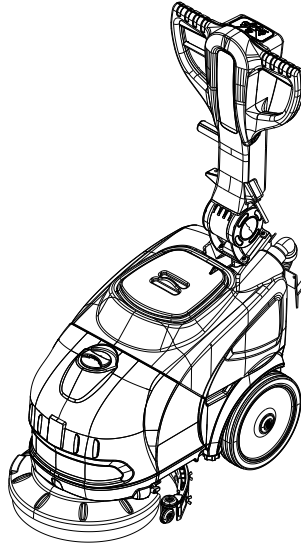

CT15 - Lavamatic 15



(IT) MANUALE ISTRUZIONI PER L'USO / **(EN)** OPERATOR'S MANUAL / **(FR)** MANUEL D'INSTRUCTIONS / **(DE)** BEDIENUNGSANLEITUNG / **(ES)** MANUAL DE INSTRUCCIONES / **(NO)** BRUKERHÅNDBOK / **(NL)** GEBRUIKERSHANDLEIDING / **(PT)** MANUAL DE UTILIZAÇÃO / **(SE)** INSTRUKTIONSBOK / **(RU)** РУКОВОДСТВО ОПЕРАТОРА / **(BG)** РЪКОВОДСТВО ЗА ЕКСПЛОАТАЦИЯ / **(DK)** BETJENINGSMANUAL / **(FI)** KÄYTTÖOPAS / **(CN)** 操作手册 / **(HU)** HASZNÁLATI ÚTMUTATÓ / **(PL)** PODRĘCZNIK OPERATORA / **(SL)** PRIRUČNIK Z NAVODILI ZA UPORABO / **(CZ)** NÁVOD PRO OBSLUHU / **(HR)** PRIRUČNIK ZA KORIŠTENJE / **(LT)** OPERATORIAUS VADOVAS / **(LV)** OPERATORA ROKASGRĀMATA / **(SK)** NÁVOD NA POUŽITIE / **(RO)** MANUAL DE UTILIZARE / **(TR)** KULLANIM KILAVUZU / **(EE)** KASUTUSJUHEND / **(GR)** ΕΓΧΕΙΡΙΔΙΟ ΧΡΗΣΤΗ / **(JP)** 取扱説明書 / **(KR)** (영) 사용설명서

Consultare attentamente questo manuale prima di procedere a qualsiasi intervento sulla macchina

Read this manual carefully before carrying out any work on the machine

Lire attentivement ce manuel avant toute intervention sur la machine

Vorliegendes Handbuch vor jedem Eingriff an der Maschine aufmerksam durchlesen

Consulte detenidamente este manual antes de llevar a cabo cualquier trabajo en la máquina

Konsulter denne håndboken nøye før du går i gang med noen som helst type inngrep på maskinen

Raadpleeg deze handleiding aandachtig alvorens met enige werkzaamheid aan de machine te beginnen

Consulte atentamente este manual antes de efectuar cualquier intervención na máquina

Läs noggrant igenom denna handbok innan du utför något som helst inngrep på maskinen

Внимательно ознакомьтесь с данной инструкцией до проведения любой работы с машиной

Las denne brugsanvisning omhyggeligt, inden du udfører arbejde på maskinen.

Lue tämä opas huolellisesti ennen minkään toimenpiteen suorittamista koneelle.

操作机器之前请认真阅读本手册

A géppel történő munkavégzést megelőzően figyelmesen olvassa el ezt az útmutatót

Przed rozpoczęciem pracy z urządzeniem należy uważnie przeczytać niniejszy podręcznik

Pozorno preberite to navodilo za uporabo, preden se lotite kakršnega koli poseganja v stroj

Před jakoukoli manipulací se strojem si nejdříve pozorně přečtěte tento návod.

Pažljivo pročítajte ovaj priručnik prije izvođenja bilo kakvih radnji na uređaju.

Idémiai perskaiyk ite šį vadovą prieš atlikdami bet kokius darbus su mašina

Pirms uzsāk jebkuru darbu ar šo iekārtu, rūpīgi izlasiet šo rokasgrāmatu.

Tento návod si pozorne přečítajte pred každým zásahom na stroji.

Cititi cu atentie acest manual inainte de a efectua orice operatiuni asupra masinii

Makine ile herhangi bir işlemler yapmadan önce bu kılavuzu dikkatle okuyun

Enne masina kasutamise alustamist lugege see juhend põhjalikult läbi.

Διαβάστε προσεκτικά αυτό το εγχειρίδιο προτού χρησιμοποιήσετε το μηχάνημα.

本機を使用する前に本説明書をよくお読みください。

본 제품을 사용하기 전 해당 설명서의 내용을 숙지하여 주십시오.

ENGLISH
**(Translation of original
instructions)**



TECHNICAL SPECIFICATIONS	4
MACHINE DIMENSIONS	6
IMPORTANT SAFETY PRECAUTIONS	7
SAFETY SYMBOLS	12
FIGURE	14
GENERAL INFORMATION	19
Purpose of this manual	19
Identifying the machine	19
Documentation provided with the machine	19
TECHNICAL INFORMATION	20
General description	20
Parts of the machine	20
Danger zones	20
Accessories	20
MOVEMENT INSTALLATION	21
Lifting and transporting the packaged machine	21
Delivery checks	21
Unpacking	21
Electrical connections and earth (mains powered versions)	21
Power supply batteries (battery powered versions)	22
Batteries: preparation	22
Batteries: installation and connection	22
Batteries: removal	23
Lifting and transporting the machine	23
PRACTICAL GUIDE FOR THE OPERATOR	23
Controls - Description	23
Mounting and adjusting the squeegee	24
Moving the machine when not in operation	24
Mounting and changing the brush/drive disks	25
Detergents - Instructions	25
Preparing the machine for work	25
Working	26
At the end of work:	26
Some useful tips to get the most from your scrubber drier	26
Draining the dirty water	27
Draining the clean water	27
PERIODS OF INACTIVITY	27
BATTERY MAINTENANCE AND CHARGING	27
MAINTENANCE INSTRUCTIONS	28
Maintenance - General rules	28
Routine maintenance	28
Squeegee blades: replacing	28
Fuses: replacing	29
Routine maintenance	29
Six monthly operations	29
Maintenance	30
TROUBLESHOOTING	31
How to resolve possible problems	31
ERROR CODE DISPLAY, BATTERY VERSION	32

TECHNICAL SPECIFICATIONS

		B (battery power)	C (mains power)
Cleaning width	mm	350	
	inch	14	
Squeegee width	mm	450	
	inch	17,7	
Cleaning capacity per hour	m ² /h	1300	
	ft ² /h	13993	
Number of brushes	n°	1	
Brush diameter	mm	355	
	inch	14	
Maximum brush pressure	g/cm ²	/	
Brush rotation speed	g/1° - RPM	140	140
Brush motor power	W	200	250
	HP	0,26	0,33
Drive motor power	W	/	
Maximum speed	Km/h	/	
Suction motor power	W	550	400
	HP	0,73	0,53
Solution tank	L	15	
	gal	4	
Dirty water tank	L	16,5	
	gal	5	
Rear wheel diameter	mm	250	
	inch	9,84	
Maximum slope	%	2	
Gross weight	Kg	58	38,5
	lbs	127,86	84,87
Transported weight	Kg	36	15
	lbs	79,36	33,06
Machine dimensions	mm	X=787 Z=1165 Z1=690 Y=468	
	inch	X=30,98 Z=45,86 Z1=27,1 Y=18,42	

Battery compartment dimensions (length, width, height)	mm	205x265x205	/
	inch	8,0x10,4x8,0	/
Packed size (length, width, height)	mm	800x450x640	
	inch	31,4x17,7x25,1	
Sound pressure (EN 60704)	LpA (dBA)	≤70	≤70
Measurement uncertainty	K (dBA)	2,5	2,5
Vibration level (hand) (IEC 60335-2-72)	ahv m/sec ²	≤2,5	≤2,5
Measurement uncertainty, k	m/sec ²	0,5	0,5
Vibration level (body)	HBV m/sec ²	/	/
Measurement uncertainty, k	m/sec ²	/	/
Maximum water and detergent temperature	°C	4 - 35	
	°F	39 - 95	
Battery charger	V	100 - 240	/
	Hz	50 - 60	/
	A	1,35	/
Number of batteries	n°	2	/
Battery voltage	V	12	/
Individual battery capacity	Ah (5h)	29	/
Power system voltage	V	24	115
			220 - 240
Rated current	A	31	/
Power supply frequency	Hz	/	50 - 60
Rated power	W	750	960
IP Index of Protection	IP	IPX3	

Gross weight: maximum allowable weight with the machine fully loaded and ready for use. The gross weight of the vehicle includes, when applicable, full clean water tanks, empty dirty water tanks (half full in the case of recycling systems), empty dust bags, the hopper filled to its rated capacity, the largest recommended batteries and all accessories such as cables, hoses, detergent, mops and brushes.

Transported weight: the weight of the machine including the batteries, but excluding optionals (for example, the operator's cabin, FOPS, second and third side brushes and front brush attachment), fresh water (in the case of scrubbers or combined machines) and the weight of a standard operator (75 kg)

Data subject to variation without warning.

MACHINE DIMENSIONS

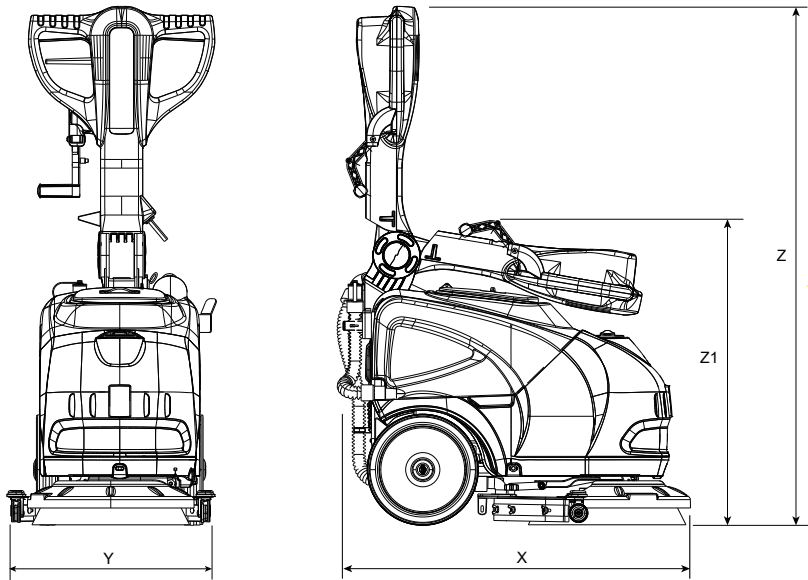

X-Y-Z: See "TECHNICAL SPECIFICATIONS" table

IMPORTANT SAFETY **PRECAUTIONS**

Basic safety precautions must be followed when using any electrical equipment.

READ ALL INSTRUCTIONS BEFORE OPERATING THIS MACHINE

WARNING! - To minimise the risk of electrocution or injury:

- a) Never leave the machine unsupervised when connected to the mains power supply. Disconnect the machine from the mains power socket after use or before performing maintenance.
- b) Never allow the machine to be used as a toy. Be extremely vigilant whenever the machine is operated by or near children.
- c) Only use the machine as instructed in this manual. Only use the accessories recommended by the manufacturer.
- d) Do not use the machine if the power cable or plug is damaged. If the machine does not function as it should or has been dropped, damaged, left outdoors or has fallen in water, have it checked and repaired by a specialist service centre.
- e) Do not move or transport the machine by pulling on its power cable. Do not use the power cable as a handle, close doors on it or pull it over sharp objects or corners. Do not run over the power cable with the machine. Keep the power cable well clear of hot surfaces.
- f) Do not disconnect the machine by pulling on the power cable. Grip the plug, not the cable, to disconnect the machine.
- g) Never touch a mains powered machine with wet hands.
- h) Do not insert objects into the ventilation slots. Do not operate the machine

with blocked ventilation slots. Remove all dust, dirt, hair and debris that might be blocking the air flow.

i) Keep hair, loose garments, fingers and all other parts of the body well clear of slots and moving parts.

l) Switch off all controls before unplugging the machine.

m) Take particular care when cleaning stairs.

n) Do not use the machine to clean up flammable or combustible liquids like petrol, and do not operate the machine in areas where such liquids may be present.

The machine must not be used for purposes other than those for which it was expressly designed.

Scrupulously respect all safety standards and conditions applicable to the type of building in which the machine is to be operated (e.g.: pharmaceutical companies, hospitals, chemicals, etc.).

Do not operate the machine in inadequate lighting, explosive atmospheres, on public roads or to clean dirt that is hazardous to health (dust, gas, etc.).

The machine must be kept indoors at all times.

The machine is designed to operate in temperatures between +4°C and +35°C. It can be stored in temperatures between +0°C and +50°C when not in use.

The machine must be used at an altitude below 2000 m.

The machine is designed to operate at relative humidity levels between 0% and 95%.

The machine must be used exclusively by persons trained in its use and/or who have demonstrated their ability and have been expressly authorised to use it.

The machine is not intended for use by persons (including children) with reduced physical, sensory or mental capabilities, or lack of experience and knowledge, unless they are supervised by a person responsible for their safety and have received instruction in the use of the machine.

Never use detergents other than those specified. Follow the instructions on the relative safety sheet.

We recommend keeping detergents out of reach of children. In the event of contact with the eyes, wash immediately with abundant water. If ingested, consult a doctor immediately.

Numerous unpleasant experiences have shown that a wide range of personal objects may cause serious accidents. Before beginning work, remove jewellery,

watches, ties, etc.

The operator must always use personal protection devices: protective apron or overalls, non-slip waterproof shoes, rubber gloves, protective goggles and ear protectors and mask to protect the respiratory tract.

Do not pick up burning or smoking material like cigarettes, matches or hot ashes.

Never operate the machine on slopes or ramps of more than 2%. Never drive across even gentle slopes. Always manoeuvre with care and avoid reversing.

If you need to transport the machine over ramps or steep slopes, to prevent it tipping over or running out of control, completely empty the detergent and dirty water tanks and remove the batteries.

Never park the machine on a slope.

Never leave the machine unattended while switched on. Before leaving it, disconnect the machine from the mains power supply and make sure it cannot move accidentally.

Never use the machine to transport people or goods or to tow things. Do not tow the machine.

Never rest objects of any weight on the machine for any reason.

Do not remove, modify or bypass safety devices (brush guards, battery covers, fuses, electric system covers, etc.).

Always check the condition of the brush guard before operating the machine. If any damage is found, do not operate the machine but have the guard replaced by personnel trained and authorised by the manufacturer.

Never touch the brush unless the machine is disconnected from the power supply.

The fluids collected during work contain detergent, disinfectant, water and organic and inorganic material. They must be disposed off in accordance with current legislation.

Never wash the machine with water jets.

Make sure the electrical characteristics of the machine (voltage, frequency, power) given on the nameplate correspond to those of the mains electricity supply.

Make sure the power sockets used for mains powered models and battery chargers are properly earthed and protected by a 2-pole thermal magnetic switch with differential circuit-breaker:

- ▶ rated current 15-16A
- ▶ $I\Delta n$ differential current: 0.03A
- ▶ I_{cn} breaking capacity: 6000 A

► AC differential breaker intervention

This equipment must be earthed. In the event of a malfunction or failure, the earth connection provides the path of least resistance for electrical current, minimising the risk of electrocution.

Mains powered versions come with a three-wire cable and a three-pin earthed plug for use in a suitable earthed socket. The earth wire is yellow and green. Never connect this wire to anything other than the earth terminal of the socket. The plug must be plugged into a suitable socket, correctly installed and wired according to local standards.

Incorrect wiring or failure to connect the machine's earth wire may lead to a risk of electrocution.

If you are in doubt about the proper earthing of the power socket, have it checked by a qualified electrician.

Do not tamper with the plug supplied with the machine. Only use sockets that are suitable for the machine's mains plug. If the plug needs to be replaced, have the job done by a qualified electrician.

Use of adapters with the machine's mains power plug is strictly forbidden.

When operating mains powered versions, to avoid the risk of electrocution, use only the extension supplied with the machine.

When using mains powered versions, take care to prevent the rotating brush from coming into contact with the power cable.

To reduce the risk of personal injury caused by the machine's power plug becoming loose in the extension, periodically check that the connection is secure. Using an extension with a loose connection can cause overheating, smoke and even fire.

To reduce the risk of the machine's mains power plug becoming loose in the extension, tie a knot as shown (fig. M), or secure the machine's power cable to the clip on the machine's handle as shown (fig. N).

When operating mains powered versions, periodically examine the mains cable and extension. If any damage is detected, do not use the machine and refer the necessary repairs to personnel trained and authorised by the manufacturer. Battery charger: check the power cable regularly for damage. In the event of damage, do not use the machine. Have the cable replaced by personnel trained and authorised by the manufacturer.

Use only the battery charger supplied with the machine to recharge the batteries.

It is essential to respect the battery manufacturer's instructions.

- Always keep the batteries clean and dry to avoid surface leakage currents.
- Protect the batteries from impurities such as metal dust.
- Never rest metal tools on batteries as they could cause short circuits and

lead to explosions.

- ▶ Never wear metal rings or bracelets when working on batteries.
- ▶ Do not smoke, use naked flames or sparks near batteries.
- ▶ Never lift or handle batteries by their terminals.
- ▶ Batteries must be disposed of through appropriate channels and not as normal waste.
- ▶ In the case of gel batteries, never attempt to remove the battery cover to add water or acid to the cell/s inside.
- ▶ When using acid for leak-proof tubular batteries, always follow the safety instructions scrupulously.
 - ▶ The electrolyte contained in batteries is a sulphuric acid solution and is highly corrosive.
 - ▶ In the event of contact with the eyes, wash immediately with plenty of water and seek medical advice
 - ▶ In the event of contact with the skin or clothing, wash with plenty of water.
 - ▶ Store out of the reach of children.
 - ▶ Use suitable gloves and protect the eyes and face.
 - ▶ Make sure that the area is well ventilated before recharging batteries.













All maintenance operations must be performed in an adequately lit place and only after disconnecting the machine from the power supply. With mains powered models, unplug the machine from the mains power socket. With battery models, remove the fuse from the battery bridge. With mains powered models, the operator must always be in a position to verify that the plug remains unplugged from the mains power socket throughout maintenance operations.



All work on the electrical system and all maintenance and repair operations other than those explicitly described in this manual must be performed by personnel trained and authorised by the manufacturer.

If the power cable, plug or terminals require replacing, make sure the electrical connections and cable grip are tightly fastened to guarantee the resistance of the cable if pulled.

KEEP THESE INSTRUCTIONS SAFE.

SAFETY SYMBOLS

	<p>MAXIMUM SLOPE</p>
	<p>OPERATOR'S MANUAL, INSTRUCTIONS FOR USE</p>
	<p>READ THE OPERATOR'S MANUAL</p>
	<p>DIRECT CURRENT SYMBOL</p>
	<p>INSULATION CLASS. THIS CLASSIFICATION ONLY APPLIES TO BATTERY POWERED MACHINES.</p>
	<p>EARTH SYMBOL, IDENTIFIES ANY TERMINAL DESTINED FOR CONNECTION TO AN EXTERNAL EARTH CONDUCTOR TO PROTECT AGAINST ELECTROCUTION IN THE EVENT OF A MALFUNCTION.</p>
	<p>MACHINE RUN SYMBOL</p>
	<p>MACHINE STOP SYMBOL</p>
	<p>MACHINE STANDBY SYMBOL</p>
	<p>SPECIAL WASTE. DO NOT DISPOSE OF AS NORMAL WASTE.</p>
	<p>CAUTION! RISK OF ABRASION</p>
	<p>MINIMUM AND MAXIMUM TEMPERATURE OF LIQUID IN TANK</p>

	CAUTION! PROTECT AGAINST RAIN
	CAUTION! PROTECT AGAINST DIRECT SUNLIGHT
 24V DC	ARRANGEMENT AND CONNECTION OF BATTERIES

FIGURE

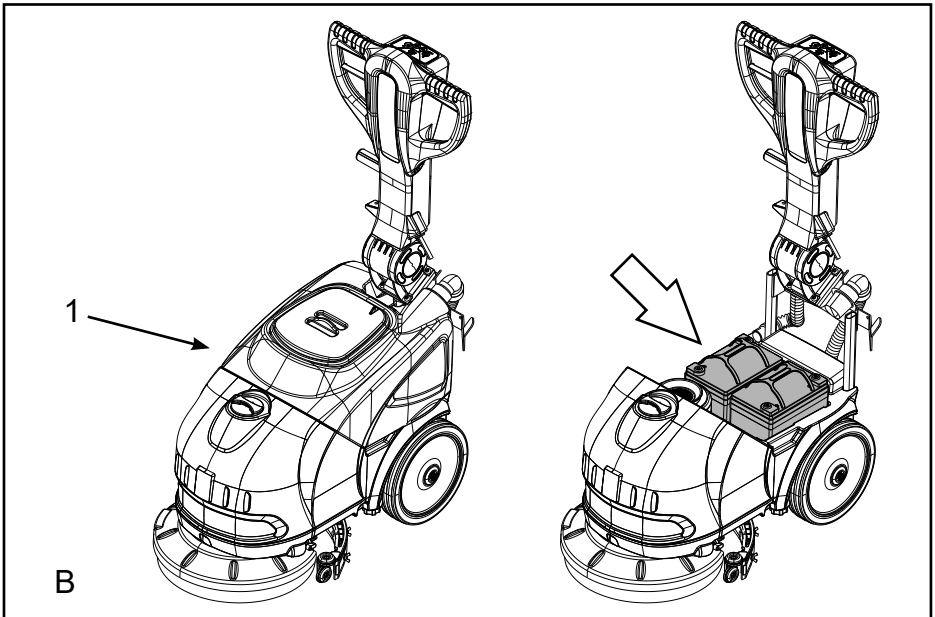
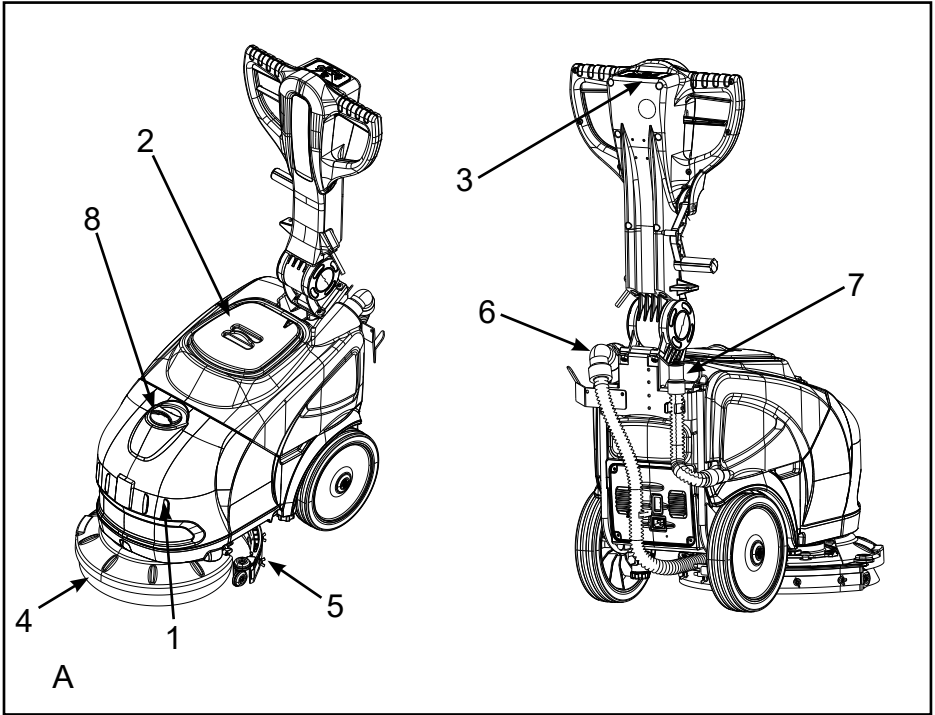

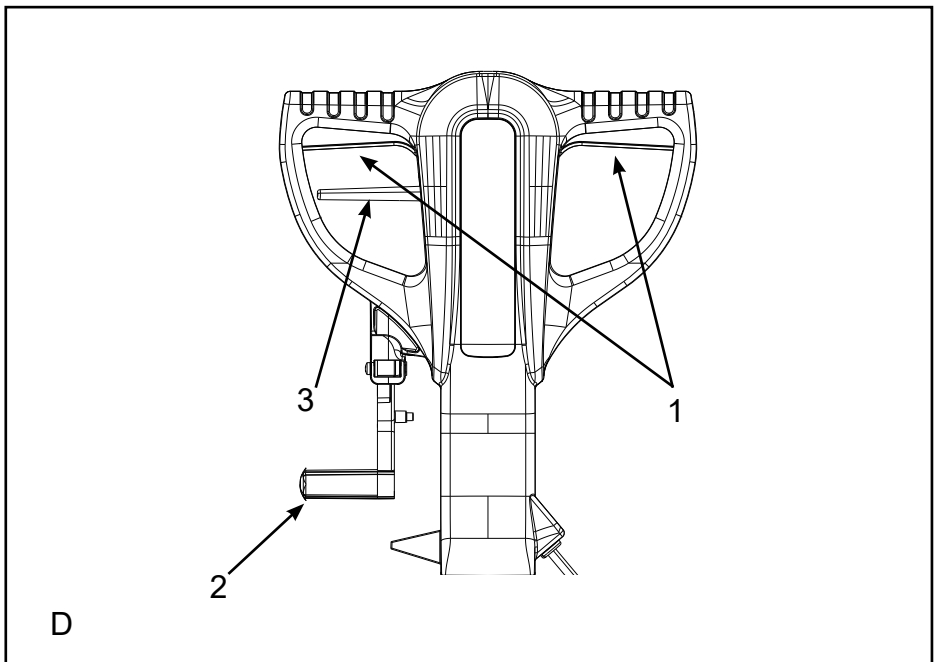
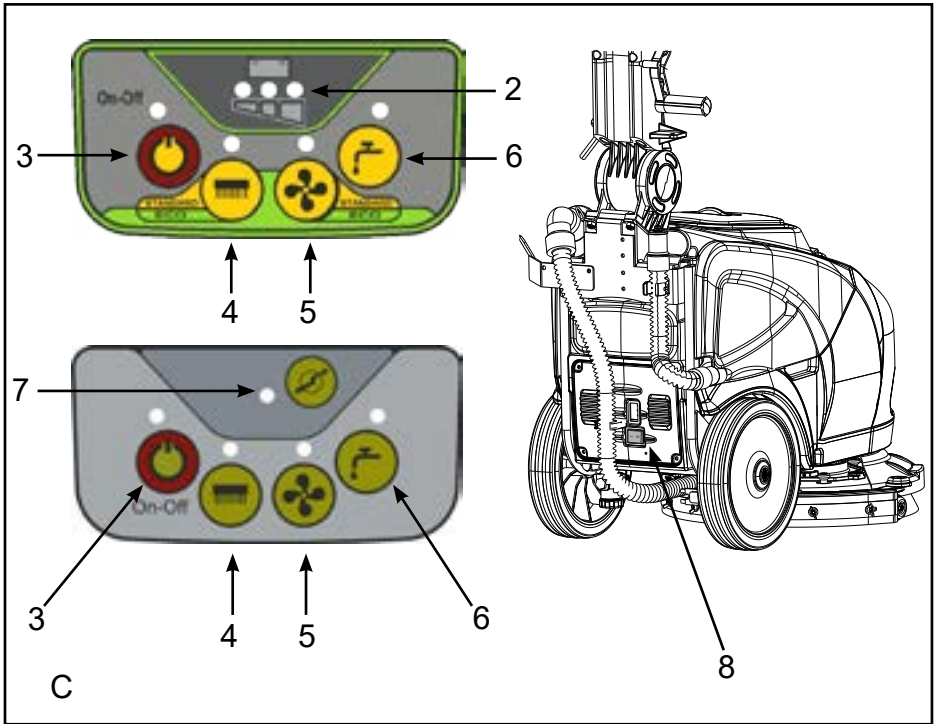

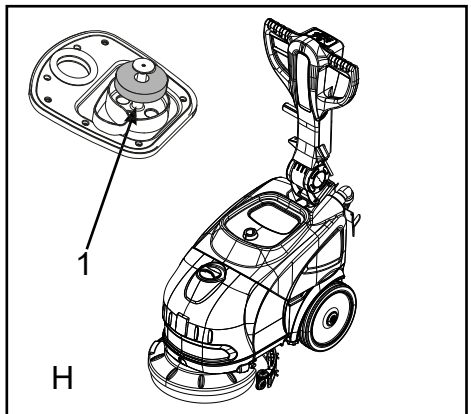
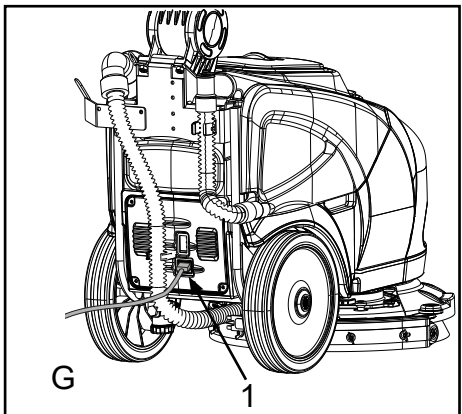
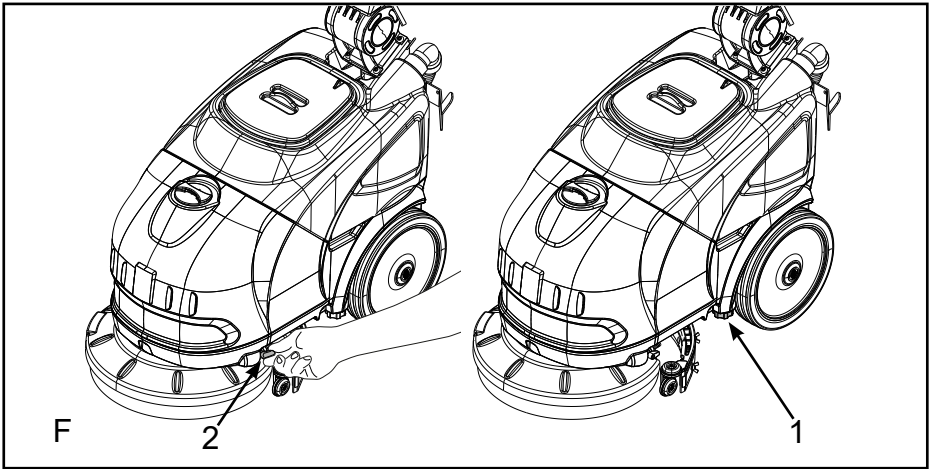
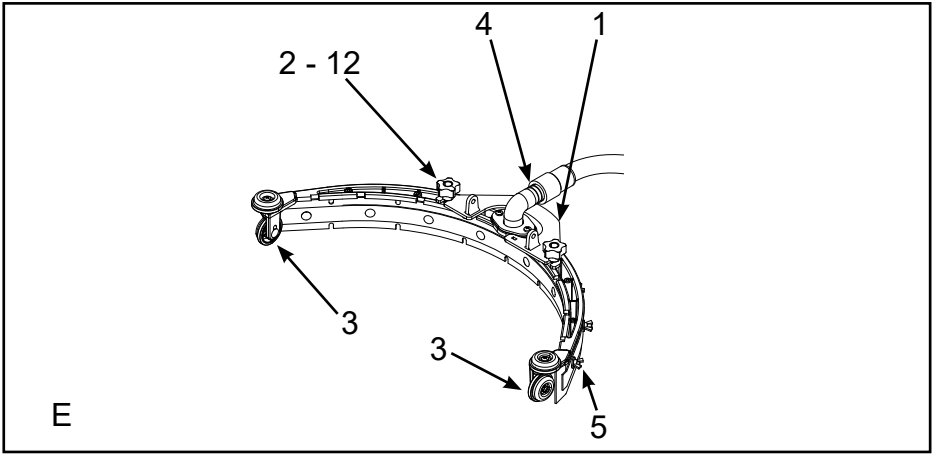

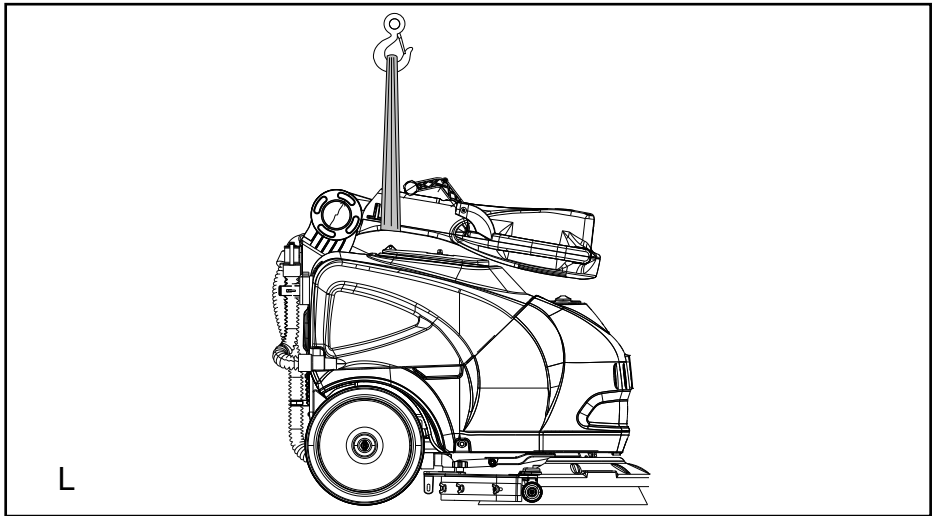
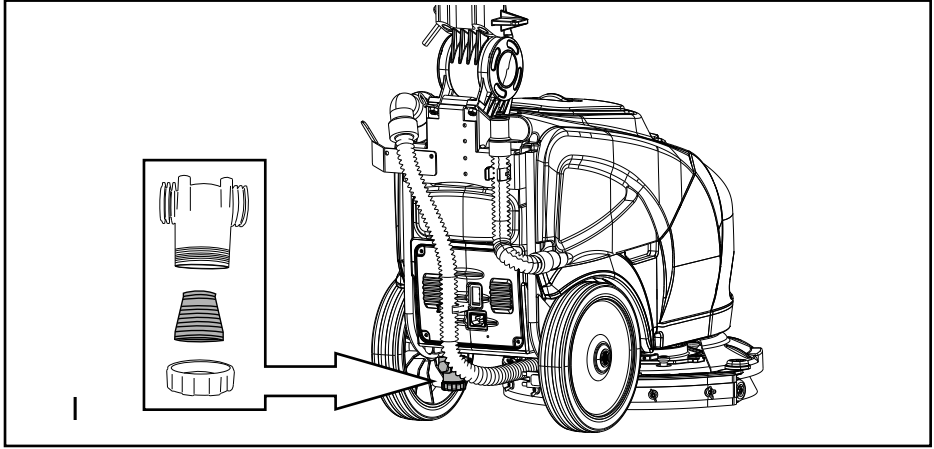

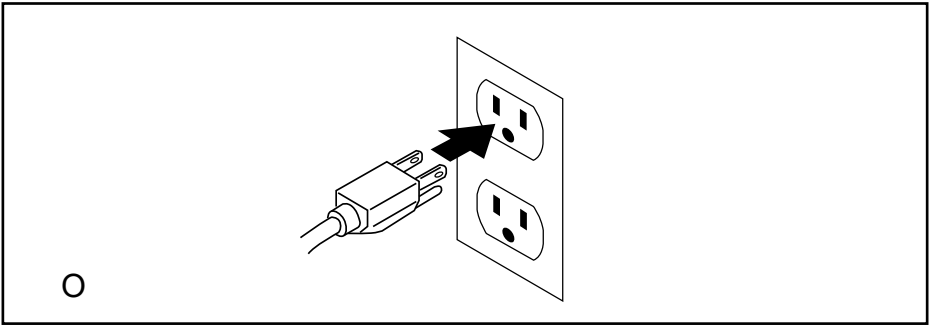
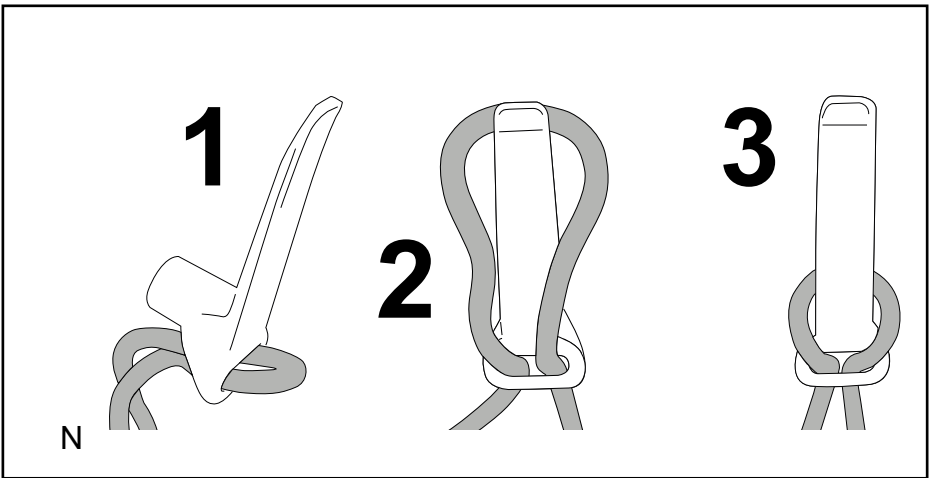
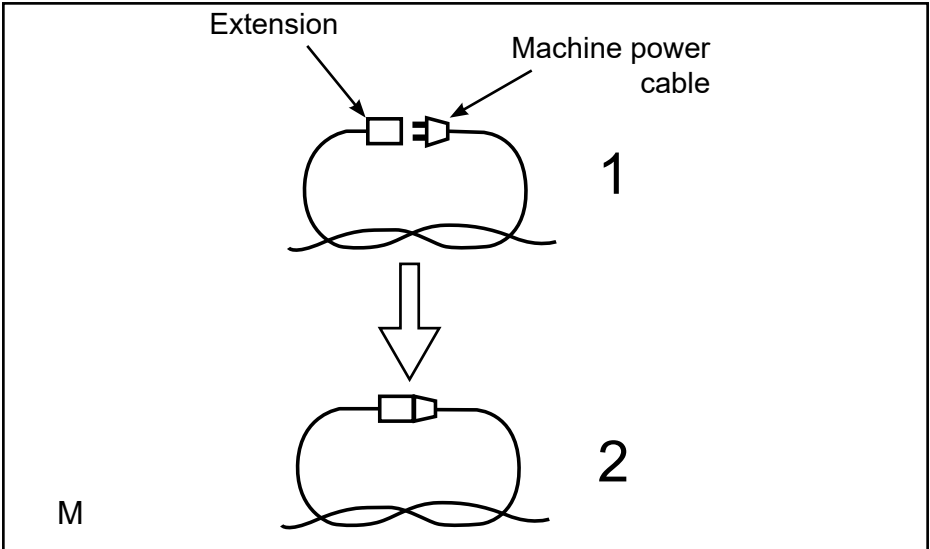

GENERAL INFORMATION

IMPORTANT!

Read this manual carefully before carrying out any work on the machine.

Purpose of this manual

This manual has been written by the Manufacturer and is an integral part of the **machine**¹.

It defines the purpose for which the machine has been designed and constructed and contains all the information required by **operators**².

In addition to this manual, which contains information for operators, other publications are available providing specific information for **maintenance personnel**³.

The terms "right" and "left", "clockwise" and "anti-clockwise" refer to the forward movement of the machine.

Constant compliance with the instructions provided in this manual guarantees the safety of the operator and the machine, ensures low running costs and high quality results and extends the working life of the machine. Failure to follow these instructions may lead to injury to the operator or damage to the machine, floor and environment.

Consult the table of contents at the beginning of the manual to find the section you need rapidly.

Parts of the text requiring special attention are printed in bold and preceded by the symbols illustrated and described here.

DANGER

Indicates the need for attention in order to avoid a series of consequences which could cause death or serious injury to personnel.

WARNING

Indicates the need for attention in order to avoid a series of consequences which could cause injury to personnel or damage to the machine or work environment or financial loss.

IMPORTANT!

Indicates particularly important instructions.

In line with the company's policy of constant product development and updating, the Manufacturer reserves the right to make modifications without prior notice.

Although your machine may differ appreciably from the illustrations in this document, the correctness and validity of the instructions contained in this manual are guaranteed.

Identifying the machine

The nameplate provides the following information:

- ▶ model;
- ▶ power supply;
- ▶ total nominal power;
- ▶ serial number;
- ▶ year of fabrication;
- ▶ dry weight;
- ▶ maximum slope;
- ▶ manufacturer's identification.

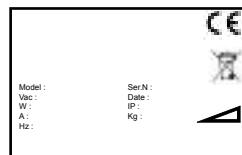

Documentation provided with the machine

- ▶ operator's manual;
- ▶ guarantee certificate;
- ▶ EC certificate of conformity.

1 The definition "machine" replaces the trade name covered by this manual.

2 Persons responsible for using the machine without performing any operations requiring precise technical skills.

3 Persons with experience, technical training and a knowledge of legislation and standards, able to perform all the necessary operations and to recognise and avoid possible risks in handling, installation, use and maintenance of this machine.

TECHNICAL INFORMATION

General description

This machine is a scrubber drier destined for sweeping, washing and drying flat, horizontal, smooth or moderately rough, even and obstacle-free floors.

The machine is intended for use in commercial applications, such as hotels, schools, hospitals, factories, shops and offices, or for hire.

The machine must only be used indoors.

It is available in both battery and mains powered versions to meet all running time and weight requirements.

The scrubber drier spreads a solution of water and detergent in the correct concentration on the floor and then scrubs it to remove the dirt. By carefully choosing the detergent and brushes (or abrasive disks) from the wide range of accessories available, the machine can be adapted to a wide range of combinations of types of floor and dirt.

A suction system incorporated in the machine dries the floor after washing by means of the low pressure generated in the dirty water tank by the suction motor. The squeegee connected to the tank collects the dirty water.

Parts of the machine

The main parts of the machine are as follows (fig. A):

- ▶ the detergent tank (fig. A, ref. 1): contains and transports the mixture of clean water and detergent;
- ▶ the dirty water tank (fig. A, ref. 2): collects the dirty water picked up from the floor after washing;
- ▶ control panel (fig. A, ref. 3);
- ▶ head assembly (fig. A, ref. 4): the main element is the brush which distributes the detergent solution on the floor and remove the dirt;
- ▶ squeegee assembly (fig. A, ref. 5): wipes and dries the floor by collecting the water.

Danger zones

- ▶ Tank assembly: when using certain detergents, danger of irritation for eyes, skin, mucous membranes and respiratory tract and of asphyxia. Danger represented by the dirt collected from the environment (germs and chemical substances). Danger of crushing between the two tanks when the dirty water tank is replaced on top of the detergent tank.
- ▶ Control panel: risk of injury from short circuits.
- ▶ Bottom of washing head: danger due to brush rotation.
- ▶ Rear wheels: danger of crushing between the wheel and chassis.
- ▶ Battery compartment (in the detergent tank): danger of short circuit between the battery poles and presence of hydrogen during charging.

Accessories

DANGER

Before fitting the accessories listed below, disconnect the plug from the mains power socket (mains powered versions) or switch the machine off (battery powered versions).

IMPORTANT!

For a complete and up-to-date list of available accessories, contact an authorised dealer.

- ▶ Bristle brushes: for washing delicate floors and polishing;
- ▶ Polypropylene brushes: for normal floor washing;
- ▶ Tynex brushes: for removing accumulated stubborn dirt on resistant floors;
- ▶ Drive disks: enable the following disks to be used:
 - ▶ Yellow disks: for washing and polishing marble and similar surfaces;
 - ▶ Green disks: for washing resistant floors;
 - ▶ Black disks: for thorough washing of resistant floors with stubborn dirt;
- ▶ S.P.E. battery charger CBHD1

MOVEMENT INSTALLATION

Lifting and transporting the packaged machine

WARNING

During all lifting operations, make sure the packaged machine is firmly secured to avoid it tipping up or being accidentally dropped.

Always load/unload lorries in adequately illuminated areas.

The machine is packaged on a wooden pallet by the Manufacturer. It must be loaded on to the transporting vehicle using suitable equipment (see EC Directive 89/392 and subsequent amendments and/or additions). At destination, it must be unloaded using similar means.

A fork lift truck must always be used to lift the packaged body of the machine. Handle with care to avoid knocking or overturning the machine.

Delivery checks

When the carrier delivers the machine, make sure the packaging and machine are both whole and undamaged. If the machine is damaged, make sure the carrier is aware of the damage and before accepting the goods, reserve the right (in writing) to request compensation for the damage.

Unpacking

WARNING

When unpacking the machine, the operator must be provided with the necessary personal protection devices (gloves, goggles, etc.) to limit the risk of injury.

Proceed as follows to unpack the machine.

- ▶ cut and remove the plastic straps using scissors or nippers;
- ▶ open the packaging;
- ▶ remove the machine from the packaging, lifting it with the handle folded forwards in the position shown in the figure (fig. L), using a strap and hoist to do so. Make sure that the machine remains stable and horizontal while lifting then lower it to the floor.
- ▶ remove the bags included in the packaging and check the contents:
 - ▶ guarantee slip;
 - ▶ use and maintenance manual;
 - ▶ battery bridges with terminals (battery powered versions only);
 - ▶ extension power cable (mains powered version);
- ▶ clean the outside of the machine in respect of safety regulations;
- ▶ after unpacking the machine, install the batteries (battery versions) or connect the electrical connections (mains powered versions). See relevant sections.

The packaging may be kept and reused to protect the machine if it is moved to another site or to a repair workshop.

Otherwise it must be disposed of in compliance with current legislation.

Electrical connections and earth (mains powered versions)

The electrical characteristics of the machine are given on the rating plate. Make sure the frequency and voltage correspond to those of the mains supply where the machine will be operated. As far as voltage is concerned, models on which the rating plate specifies a voltage of 230 V can be used with voltages between 220 V and 240 V. Similarly, models rated at 115 V can be used between 110 V and 120 V. To avoid the risk of electrocution, only use the extension cable supplied with the machine, which has an earth connection like that shown in the figure (fig. O). Make sure that the machine is connected to a socket with the same configuration as the plug.

Do not use an adapter with this machine.

The frequency on the plate must always correspond to the mains voltage.

WARNING

Make sure the mains system is suitably earthed and that sockets ensure the continuity of the earth conductors.

DANGER

Failure to observe these instructions could cause possibly serious damage to people and things and invalidates the guarantee.

Power supply batteries (battery powered versions)

DANGER

To avoid the risk of electrocution, batteries must be installed by the manufacturer or by personnel trained and authorised by the manufacturer.

Two different types of battery may be installed on these machines:

- ▶ leak-proof tubular batteries: these require regular checks on electrolyte level. When necessary, top up with distilled water until the plates are covered. Do not over-fill (5 mm max. above the plates).
- ▶ gel batteries: this type of battery is maintenance-free. Technical characteristics must correspond to those indicated in the machine technical specifications section. The use of heavier batteries could seriously jeopardise manoeuvrability and lead to the brush motor overheating. Batteries with a lower capacity and weight will require charging more frequently. Batteries must be kept charged, dry, clean and with tight terminals.

Batteries: preparation

DANGER

During installation of the batteries or any type of battery maintenance, the operator must be provided with the necessary personal protection devices (gloves, goggles overalls, etc) to limit the risk of accident. Keep away from naked flames, avoid short circuiting the battery poles, avoid sparks and do not smoke.

Batteries are normally supplied filled with acid and ready for use.

If the batteries are dry, proceed as follows before installing them in the machine.

- ▶ remove the caps and fill all elements with specific sulphuric acid solution (see the table below) until the plates are entirely covered (this requires at least a couple of passes for each element);

Ambient temperature °C	Ambient temperature °F	% Sulphuric acid	% Distilled water
> + 35°C	> + 95°F	25%	75%
from 0°C to + 35°C	from +32°F to + 95°F	30%	70%
from 0°C to - 20°C	from +32°F to - 4°F	40%	60%
< - 20°C	< + 4°F	45%	55%

- ▶ leave for 4-5 hours to allow the air bubbles to come to the surface and the plates to absorb the electrolyte;
- ▶ make sure the level of electrolyte is still above the plates and if necessary top up with sulphuric acid solution;
- ▶ close the caps;
- ▶ mount the batteries on the machine (following the procedure described below).

Before starting up the machine for the first time, charge the batteries as follows.

Batteries: installation and connection

DANGER

Check that all switches on the control panel are in the "0" (off) position.

Make sure you connect the terminals marked with a "+" to the positive poles of the battery. Do not check the battery charge by sparking.

Meticulously follow the instructions given below as short circuiting the batteries could cause them to explode.

- ▶ Make sure the dirty water tank is empty and empty it if necessary (see relevant paragraph).
- ▶ Remove the dirty water tank (fig. B, ref. 1) off the detergent tank by pulling it upwards, making sure you have previously removed the suction hose and dirty water tank drain hose from their housings.
- ▶ When installing and connecting batteries, always refer to the drawing on the detergent tank.

WARNING

Mount the batteries on the machine using lifting means suitable for their weight.

The positive and negative poles have different diameters.

- ▶ Connect the battery wiring and bridge terminals to the battery poles.
- ▶ Tighten the terminals on the poles and cover with Vaseline.
- ▶ Put the dirty water tank back on the detergent tank.
- ▶ When using the machine, follow the instructions below.

Batteries: removal

DANGER

When removing the batteries, the operator must be equipped with suitable personal protection devices (gloves, goggles, overalls, safety shoes, etc) to reduce the risk of accidents. Make sure the switches on the control panel are in the "0" position (off) and the machine is turned off. Keep away from naked flames, do not short circuit the battery poles, do not cause sparks and do not smoke. Proceed as follows:

- ▶ disconnect the battery wiring and bridge terminals from the battery poles.
- ▶ if necessary, remove the devices fixing the battery to the base of the machine.
- ▶ Lift the batteries from the compartment using suitable lifting equipment.

Lifting and transporting the machine

WARNING

All phases of lifting and moving must be performed in an adequately illuminated environment with the adoption of the safety measures most appropriate to the situation. The operator must always use personal protection devices.

To load the machine onto a means of transport, proceed as follows:

- ▶ empty the dirty water and detergent tanks;
- ▶ place the packaging on the pallet.
- ▶ place the machine in the packaging, lifting it with the handle folded forwards in the position shown in the figure (fig. L), using a strap and hoist to do so. Keep the machine stable and horizontal during lifting.
- ▶ fix the packaging to the pallet with plastic straps;
- ▶ lift the pallet (with the machine) using a fork lift truck and load it onto the means of transport;
- ▶ anchor the machine to the means of transport with cables connected to the pallet and machine itself.

PRACTICAL GUIDE FOR THE OPERATOR

Controls - Description

With reference to fig. C, the machine has the following controls and indicator lights:

- ▶ Power on light (fig. C, ref. 7 - mains powered versions only): green, indicates that the machine's power cable is connected to the mains.
- ▶ Battery charge light (fig. C, ref. 2 - battery powered versions only): 3 LEDs (red, yellow and green) which indicate the level of battery charge. There may be:
 - ▶ red and yellow LEDs on, yellow flashing: battery voltage > 30.0 V;
 - ▶ red, yellow and green LEDs on: battery voltage from 30.0-23.3 V;

- ▶ red and yellow LEDs on: battery voltage from 23.5-22.5 V;
- ▶ red LEDs on: battery voltage from 22.5-21.9 V;
- ▶ red LED flashing: battery voltage from 21.9-21.4 V, batteries completely flat; after a few seconds the brush and suction motor shut down;
- ▶ Main switch instrument panel (fig. C, ref. 3): enables (LED on) and disables (LED off) electrical power to all machine functions (to turn the machine off, hold the button down for at least 4 seconds).
- ▶ Main Switch (fig. C, ref. 8 - mains powered versions only): enables and disables electrical power to all machine functions.
- ▶ Brush button with light (fig. C, ref. 4): enables (LED on) and disables (LED off) the “brush” function. The brush does not start rotating until the brush lever is operated. ECO function (battery powered versions only), used to reduce brush motor power by 20%, to activate this function, operate the “Brush lever” then press the button for a few seconds, until the LED starts flashing.

i INFORMATION

When the brush button is pressed, suction and detergent delivery are also enabled automatically.

- ▶ Suction button with light (fig. C, ref. 5): turns the suction motor on (LED on) and off (LED off) to dry the floor being washed. The light is on when there is power to the suction motor. ECO function (battery powered versions only), used to reduce suction motor power by 20%, to activate this function, operate the “Brush lever” then press the button for a few seconds, until the LED starts flashing. Suction can be activated without operating the brush lever, by holding the button for a few seconds, until the LED starts flashing. In this mode, detergent delivery can also be activated by pressing the button (fig. C, ref. 6).
- ▶ Detergent button (fig. C, ref. 6): enables (LED on) and disables (LED off) detergent flow. The detergent does not flow unless the brush is rotating.
- ▶ Brush lever (fig. D, ref. 1): enables brush rotation.
- ▶ Squeegee lever (fig. D, ref. 2): raises (if lowered) or lowers (if raised) the squeegee.
- ▶ Handle regulation lever (fig. D, ref. 3): allows the angle of the handle to be adjusted.
- ▶ Detergent tap (fig. F, ref. 2): adjusts the flow of detergent to the brush.

Mounting and adjusting the squeegee

The squeegee (fig. A, ref. 5) is responsible for the first phase of drying.

Proceed as follows to install it:

- ▶ check that the squeegee mount (fig. E, ref. 1) is lowered, otherwise lower it by means of the squeegee lever (fig. D, ref. 2);
- ▶ tip the machine backwards and rest the handle on the floor;
- ▶ insert the two threaded pins (fig. E, ref. 12) on the squeegee into the slots on the support (fig. E, ref. 1);
- ▶ fix the squeegee by tightening the two knobs (fig. E, ref. 2).
- ▶ insert the sleeve of the suction hose (fig. E, ref. 4) fully into the squeegee;

The squeegee blades scrape the film of water and detergent from the floor and prepare the way for perfect drying. With time, the constant rubbing makes the edge of the blade in contact with the floor rounded and cracked, reducing the drying efficiency and requiring it to be replaced. The state of wear should be checked frequently.

For perfect drying, the squeegee must be adjusted in such a way that the edge of the rear blade bends during operation by about 45° with respect to the floor at every point. Adjust the height of the blade during operation by regulating the height of the wheels positioned behind and alongside the squeegee (fig. E ref. 3).

Moving the machine when not in operation

Proceed as follows to move the machine.

- ▶ lift the squeegee using the squeegee lever (fig. D, ref. 2);
- ▶ raise the front of the machine by levering on the handle and move it to the destination;
- ▶ on arrival, lower the front of the machine.

Mounting and changing the brush/drive disks

DANGER

During brush/drive disk attachment and release, pay attention to brush rotation.

WARNING

Never work without the brushes and drive disks correctly installed.

Brush/drive disk attachment: turn the machine on by pressing the main switch (fig. C, ref. 3) "LED on", then press the brush button (fig. C, ref. 4) "LED on". Rest the brush on the floor in front of the machine. Raise the front of the machine by levering on the handle, then lower it onto the brush, centring it with the brush cover. Operate the brush lever (fig. D, ref. 1) repeatedly until the brush automatically engages on the flange hub. If the manoeuvre is not successful, press on the handle again and repeat the centring and repeated operation of the brush lever.

Brush/drive disk release: turn the machine on by pressing the main switch (fig. C, ref. 3) "LED on2, then press the brush button (fig. C, ref. 4) "LED on".

Raise the front of the machine by levering on the handle, then operate the brush lever (fig. D, ref. 1) repeatedly. After a few pulses, the brush (or drive disk) is released and falls to the ground.

Detergents - Instructions

WARNING

Always dilute the detergent according to the manufacturer's instructions. Do not use sodium hypochlorite (bleach) or other oxidants, particularly in strong concentrations. Do not use solvents or hydrocarbons. The temperature of the water and detergent must not exceed the maximum indicated in the technical specification. They must be free of sand and/or other impurities.

The machine has been designed for use with low-foam biodegradable detergents made specifically for scrubber driers.

For a complete and up-to-date list of the detergents and chemical products available, contact one of the manufacturer's trained and authorised dealers.

Use products suitable for the floor and dirt to be removed only.

Follow the safety precautions concerning the use of detergents given in the section "IMPORTANT SAFETY PRECAUTIONS".

Preparing the machine for work

WARNING

Before starting work, wear overalls, ear protectors, non-slip waterproof shoes, mask to protect the respiratory tract, gloves and all other personal protection devices recommended by the supplier of the detergent used or necessitated by the work environment.

Proceed as follows before starting work.

- ▶ battery powered versions: check the battery charge (charge if necessary);
- ▶ make sure the dirty water tank (fig. A, ref. 2) is empty. If necessary, empty it;
- ▶ via the opening at the front, fill the detergent tank (fig. A, ref. 8) with a suitable concentration of clean water and low-foam detergent. Leave at least 5 cm between the surface of the liquid and the opening of the tank;
- ▶ mount the most suitable brushes or drive disks for the floor and work to be performed;
- ▶ make sure that the squeegee is securely fastened and connected to the suction hose; check that the front and rear blades are not worn.
- ▶ adjust the working height of the squeegees.

IMPORTANT!

If you are using the machine for the first time, we recommend trying it out on a large obstacle-free surface first to acquire the necessary familiarity.

Always empty the dirty water tank before filling the detergent tank again.

For effective cleaning and to extend the working life of the machine, follow a few simple rules:

- ▶ prepare the work area by removing all possible obstacles;
- ▶ begin working from the furthestmost point to avoid walking on the area you have just cleaned;
- ▶ choose the straightest possible working routes;
- ▶ divide large floors into parallel rectangular sections.

If necessary, finish off by passing a mop or rag rapidly over parts inaccessible to the scrubber drier.

Working

After setting up the machine, proceed as follows:

- ▶ Connect the machine as follows:
 - ▶ **mains powered versions:** plug the machine into the mains power socket and press the main switch (fig. C, ref. 8);
- ▶ lower the squeegee by means of the squeegee lever (fig. D, ref. 2);
- ▶ press the main switch (fig. C, ref. 3) "LED on";
- ▶ press the brush button (fig. C, ref. 4) "LED on", this will also automatically activate suction and solution flow. To extend machine operating time, the ECO function can be activated (see the paragraph "Controls - Descriptions");
- ▶ press the brush lever (fig. D, ref. 1).
- ▶ check regularly that detergent is reaching the brushes and top up if necessary;
- ▶ while working, check the quality of washing and adjust the flow of detergent to the brushes using the detergent tap (fig. F, ref. 2).

WARNING

Empty the dirty water tank each time you fill the detergent tank.

- ▶ The float switch (fig. H, ref. 1) in the dirty water tank turns suction off when the tank is full. If the switch trips, stop work and empty the tank.
- ▶ Battery powered versions: if the red LED (fig. C, ref. 2) starts flashing, the batteries are nearly flat. After a few seconds, the brush and suction motor shut down to prevent draining the batteries excessively. Charge the batteries.

At the end of work:

- ▶ release the brush lever (fig. D, ref. 1);
- ▶ turn the machine off by pressing the button (fig. C, ref. 3) for at least 4 seconds
- ▶ use the lever provided (Fig. D, ref. 2) to raise the squeegee off the floor and prevent continuous pressure from deforming the drying blades, standard version with brushes and drive disks;
- ▶ remove the brush (or drive disk) to prevent it from warping permanently;
- ▶ depending on the version, unplug from the mains socket or disconnect the batteries;
- ▶ empty and clean the dirty water tank.

Some useful tips to get the most from your scrubber drier

In the event of particularly stubborn dirt on the floor, washing and drying can be performed in two separate operations.

Prewashing with brushes or pads

- ▶ press the main switch (fig. C, ref. 3) "LED on";
- ▶ press the brush button (fig. C, ref. 4) "LED on";
- ▶ press the suction button (fig. C, ref. 5) "LED off" to turn suction off,
- ▶ operate the brush lever (fig. D, ref. 1) to enable brush rotation;
- ▶ make sure the suction motor is off and the squeegee is raised;
- ▶ begin washing.
- ▶ adjust the flow of detergent to the brush by means of the detergent tap (fig. F, ref. 2). Flow speed must be regulated according to the operator's chosen advance speed. The slower the machine moves forwards, the less water is needed.
- ▶ Persist when washing particularly dirty points to give the detergent time to perform its chemical action detaching and suspending the dirt and the brushes time to exert an effective mechanical action.

Drying

Lower the squeegee and with the suction motor on, pass over the same area washed previously. The result is equivalent to in-depth washing and subsequent ordinary maintenance will take less time.

Draining the dirty water

DANGER

Use suitable personal protection devices.

Drain the water with the machine disconnected from the power supply (mains powered versions).

The dirty water tank drain hose is at the back of the machine on the right.

To empty the tank:

- ▶ move the machine near a drain;
- ▶ detach the drain hose (fig. A, ref. 7) from its seat by holding it near the fixing spring and pulling horizontally;
- ▶ keeping the end of the hose as high as possible, remove the cap;
- ▶ lower the end of the hose gradually, controlling the intensity of the flow of water by adjusting the height from the ground;
- ▶ check the amount of dirt left in the dirty water tank and if necessary wash it out;
- ▶ close the drain hose with the cap. Check that it is tightly closed and replace the hose in its housing.
- ▶ You are then ready to wash and dry again.

Draining the clean water

DANGER

Use suitable personal protection devices.

Drain the water with the machine disconnected from the power supply (mains powered versions).

To empty the tank:

- ▶ move the machine near a drain;
- ▶ unscrew the cap (fig. F, ref. 1);
- ▶ when the detergent tank is completely empty, screw the cap back on again (fig. F, ref. 1).

i INFORMATION

The water and detergent solution can also be used to wash the dirty water tank.

PERIODS OF INACTIVITY

If the machine is not used for some time, remove the squeegee and brush (or drive disk), wash them and put them away in a dry place (preferably in a bag or wrapped in plastic film) away from dust.

Make sure the tanks are completely empty and perfectly clean.

Disconnect the machine from the power supply (depending on the version, unplug it from the mains or disconnect the fuse in the battery bridge).

Battery powered versions: charge the batteries completely before storing them. During long periods of inactivity, you should charge the batteries regularly (at least once every two months) to keep them constantly at maximum charge.

WARNING

If you do not charge the batteries regularly, they may be irreparably damaged.

BATTERY MAINTENANCE AND CHARGING

DANGER

Do not check the batteries by sparking.

The batteries give off flammable fumes. Put out all fires and hot embers before checking or topping up the battery level.

Perform the operations described below in a ventilated area.

To avoid permanent damage to the batteries, do not run them down completely. Remember that when the corresponding red light (fig. C, ref. 2) flashes on the control panel, you must charge the batteries.

Charging procedure

- ▶ connect the power cable from the on-board battery charger (fig. G, ref. 1) to the mains power socket.
- ▶ charge the batteries as described in the battery charger manual;
- ▶ on completion of charging, disconnect the cable of the on-board battery charger (fig. G, ref. 1)

MAINTENANCE INSTRUCTIONS

DANGER

Never perform any maintenance operations without first unplugging the machine from the mains (mains powered versions) or disconnecting the fuse on the battery bridge (battery versions).

In mains powered versions, the operator must be able to verify from any position that the machine remains unplugged from the mains socket while maintenance is being carried out.

Maintenance of the electrical circuit and all other operations not expressly required by this manual must be performed only by personnel trained and authorised by the manufacturer, in compliance with current safety legislation and as described in the maintenance manual.

Maintenance - General rules

Performing regular maintenance according to the Manufacturer's instructions improves performance and extends the working life of the machine.

When cleaning the machine, observe the following precautions.

- ▶ avoid the use of high pressure washers. Water could penetrate the electrical compartment or motors leading to damage or the risk of short circuit;
- ▶ do not use steam to avoid the heat warping plastic parts;
- ▶ do not use hydrocarbons or solvents as they could damage the cowling and rubber parts.

Routine maintenance

Detergent tank float and filter: cleaning

- ▶ Remove the dirty water tank cap. Clean the float switch (fig. H, ref. 1) and make sure it slides freely on its pin;
- ▶ clean the detergent tank filter (fig. I) by unscrewing the cap and extracting the filter assembly.

Squeegee blades: replacing

The squeegee blades collect the film of water and detergent from the floor and prepare the way for perfect drying. With time, the constant rubbing makes the edge of the blade in contact with the floor rounded and cracked, reducing the drying efficiency and requiring it to be replaced.

Turning or replacing the blades:

- ▶ lower the squeegee by means of the squeegee lever (fig. D, ref. 2);
- ▶ tip the machine backwards and rest the handle on the floor.
- ▶ remove the suction hose sleeve (fig. E, ref. 4) from the squeegee.
- ▶ remove the squeegee (fig. E ref. 1) from its mount by completely unscrewing the two knobs (fig. E ref. 2);
- ▶ remove the blade retainers and blades by unscrewing the knobs (fig. E, ref. 5)
- ▶ reuse the same blade by reversing the edge in contact with the floor until all four edges are worn out, or replace with a new blade, fitting it onto the screws on the body of the squeegee;
- ▶ replace the two blade retainers and the blades and screw up the knobs unscrewed previously.
- ▶ replace the squeegee in its support following the instructions in the section "Mounting and adjusting the squeegee".

Fuses: replacing

Fuses must only be replaced by personnel trained and authorised by the manufacturer.

Routine maintenance

Daily operations

After each day's work, proceed as follows:

- ▶ disconnect the machine from the power supply;
- ▶ empty the dirty water tank and clean if necessary;
- ▶ clean the squeegee blades and check for wear. If necessary, replace.
- ▶ check that the suction hole in the squeegee is not blocked, if necessary remove encrusted dirt;
- ▶ Battery powered versions: charge the batteries according to the procedure described.

Weekly operations

- ▶ clean the dirty water tank float switch (fig. H, rif. 1) and make sure it is working correctly;
- ▶ clean the suction hose;
- ▶ clean the dirty water tank and detergent tank;
- ▶ Battery powered versions: check the level of battery electrolyte and top up with distilled water if necessary.

Six monthly operations

Have the machine checked by personnel trained and authorised by the manufacturer.

Maintenance

The following table specifies the role responsible for each procedure.

O = Operator

A = personnel trained and authorised by the manufacturer.

Interval	Responsible	Parts of the machine	Description	Procedure	Lubricant/Liquid
Daily	O	1	Pad	Check, rotate or re-place	
	O	1	Brush/es	Check and clean	
	O	6	Squeegee	Clean and check for wear or damage	
	O	8	Spray shield	Check for wear or damage	
	O	2	Dirty water tank	Empty, rinse, clean float guard and waste basket	
	O	3	Solution tank	Empty, rinse	
	O	4	Heavy duty tank (optional)	Check and top up	ACD
	O	5	Automatic battery filling system (optional)	Check and top up	DW
	O	7	Batteries	Recharge if needed	
Weekly	O	7	Batteries	Check the electrolyte level	DW
	O	7	Battery compartment	Check for leakage	
	O	6	Squeegee assembly siphon (two-disc model)	Check. Clean	
50 hours	O	2	Dirty water tank lid gasket	Check for wear	
	O	9	Detergent tank filter	Remove and clean	
100 hours	O	7	Battery filling kit (optional)	Check the hoses for wear or damage	
200 hours	O	7	Batteries, terminals and cables	Check and clean	
	A	13	Steering chain	Lubricate, adjust tension and check for wear or damage	GO
	A	14	Steering cable	Check tension. Check for wear or damage	
750 hours	A	10	Suction motor	Replace the brushes	
1250 hours	A	11	Drive motor	Replace the brushes	
	A	12	Brush motors	Replace the brushes	

LUBRICANT/LIQUID

DW Distilled water

ACD Approved commercial detergent

GO SAE W90 gear oil

TROUBLESHOOTING

How to resolve possible problems

[B]= battery powered machines

[C]= mains powered machines

Possible problems affecting the whole machine.

PROBLEM	CAUSE	REMEDY
The machine does not work	[B]= the batteries are flat	[B]= charge the batteries
	[C]= the machine is not plugged into the mains socket	[C]= plug into the mains socket
	[C]= the switch (fig. C, ref.8) has not been pressed	[C]= press the switch
The brush doesn't rotate	the brush button LED is off	press the brush button
	you have not pressed the brush lever	press the brush lever
	[B] [C] the brush motor thermal cutout has tripped; the motor has overheated	[B] [C] release the brush lever, press the brush button "LED off", leave the machine to cool down for at least 45'
	[B]= the batteries are flat	[B]= charge the batteries
The brush motor has trouble in starting (mains powered versions only)	you are working with a dry brush on a very rough floor	open the detergent tap
The machine does not clean evenly	the brush or disk is worn	replace
No detergent is delivered	the detergent button LED is off	press the detergent button
	detergent tank empty	fill the detergent tank
	the brush motor is off	turn the motor on by operating the brush lever
	the hose delivering the detergent to the brush is blocked	unblock and open the circuit
	the tap is dirty or faulty	have the tap cleaned or replaced
	the solenoid valve is faulty	replace the solenoid valve
	If the filter is dirty, clean it	clean the filter
Detergent flow does not stop	the solenoid valve is faulty	replace the solenoid valve
The suction motor does not start	the suction button LED is off	press the suction button
The squeegee does not clean or has poor suction	The edge of the rubber blades in contact with the floor is worn	replace the rubber blade
	the squeegee or hose is blocked or damaged	unblock and repair the damage
	the float switch has tripped (dirty water drum), is clogged by dirt or broken	empty the dirty water drum or reset the float switch
	the suction hose is blocked	unblock the hose
	The suction hose is not connected to the squeegee or is damaged	connect or repair the hose
	there is no power to the suction motor or the motor is faulty	see: "The suction motor does not start"
The batteries do not provide the normal work time (battery powered versions only)	the electrolyte level is low	top up all the elements with distilled water as described in the instructions
	the battery charger is not working	see battery charger instructions

The battery discharges too fast during use, even though it has been charged correctly and when tested with a hydrometer at the end of recharging, it turned out to be uniformly charged (battery powered versions only)	the battery is new and does not deliver 100% of its expected capacity	the battery must be "run-in" by performing 20-30 charges and discharges to obtain maximum performance
	the machine is being used at maximum capacity for continuous periods and the working time is not sufficient	if possible, use batteries with a higher capacity or replace the batteries with others charged previously
	the electrolyte has evaporated and does not cover the plates completely	top up all elements with distilled water until the plates are covered then recharge the battery

ERROR CODE DISPLAY, BATTERY VERSION

Brush button LED (fig. C, ref. 4), 2 quick flashes / pause / 2 quick flashes.	Brush short circuit error.
Brush button LED (fig. C, ref. 4), 1 flash / pause / 1 flash.	Overcurrent error
Suction button LED (fig. C, ref. 5), 2 quick flashes / pause / 2 quick flashes.	Suction short circuit error
Suction button LED (fig. C, ref. 5), 1 flash / pause / 1 flash.	Overcurrent error
Brush button LED (fig. C, ref. 4) + suction button LED (fig. C, ref. 5), synchronised flash / pause / synchronised flash.	Electronic board temperature error
Brush button LED (fig. C, ref. 4), 4 quick flashes / pause / 4 quick flashes.	Brush thermal protector error
Battery charge yellow LED (fig. C, ref. 2), 7 quick flashes / pause / 7 quick flashes.	Machine on with battery charger powered error
Battery charge yellow LED (fig. C, ref. 2), 5 quick flashes / pause / 5 quick flashes.	Excess battery voltage error



IPC

IP Cleaning S.r.l.
Viale Treviso 63
30026 Summaga di Portogruaro
Venezia (Italy)
T: +39 0421 205511
F: +39 0421 204227
E: www.ipcworldwide.com
W: info@ipcworldwide.com

